

Circle your lab day and time.

Your name: _____

TA name: _____

Mon	Tue	Wed	Thu	Fri
8-10	10-12	12-2	2-4	4-6

Lab 8: Electromagnetic Induction and Motors

In today's lab you will explore how changing magnetic fields induce a voltage across a wire loop, a principle called induction and used in many technical devices. You will use the oscilloscope again (some useful hints about using the oscilloscope can be found at the end of these instructions). In the second part of the lab, you will build a simple motor.

PART I: INDUCED VOLTAGE USING TWO WIRE LOOPS

Recall that magnetic fields are both **created by** and **act on** moving charges. One of the ways that this happens is by the process called **induction**. Simply put, if you put a loop of wire in a **changing magnetic field** (assuming the orientation is correct), a voltage is induced between the ends of the wire. For a simple loop of wire, this can be expressed by **Faraday's law** as follows:

$$V_{\text{induced}} = -\frac{\Delta\Phi}{\Delta t}$$

where V_{induced} is the voltage difference between the ends of the wire that made the loop, and Φ is the magnetic flux (magnetic flux is simply the area of the loop times the strength of the field, or $\Phi=A*B$, assuming the orientation is correct).

Thus, $\Delta\Phi/\Delta t$ is the **rate of change** of the flux. Since the area of the loop is a constant, substituting $\Phi=A*B$, we get:

$$V_{\text{induced}} = -A \frac{\Delta B}{\Delta t}$$

You will use two wire loops to observe the phenomenon of electromagnetic induction. The first wire is used to create a changing magnetic field by applying a time-varying voltage across its ends. If you put a second wire loop close to the first one, the second will be surrounded by the changing magnetic field generated by the first loop.

- What do you expect to see when you measure the voltage across the ends of the second loop?

A. Before doing the experiment, think about the set-up and plot your expectations on the graphs.

1. Imagine we were to put a sinusoidal voltage across the ends of a loop of wire. This would drive an alternating current through the loop (call this I_1), as plotted in the first graph.

2. For the second graph, plot the B-field strength at the center of the loop (call this B_1). Think about the relation between B_1 and I_1 (magnitude, direction) and use the right-hand rule. Start with timepoints A, B, C, and D, then fill in the rest of the plot. Draw any diagrams that are helpful. Don't worry about absolute magnitude, but pay attention to direction.

3. For the third graph, plot the **local (instantaneous) slope** of the B_1 plot (i.e. $\Delta B_1/\Delta t$). Again, start with timepoints A, B, C, and D, then fill in the rest of the plot. Don't worry about absolute numbers – just get the sign and shape of the plot right.

4. Now imagine that we put a **second** loop right next to the first one, so that the wire of the second loop surrounds the changing B-field produced by the first loop. For the fourth graph, use Faraday's law to plot the voltage **induced** on the second loop (call it V_2).

Draw any diagrams that are helpful. Start with time points A, B, C, and D, then fill in the rest of the plot. Again, don't worry about absolute numbers – just get the sign and shape of the plot right.

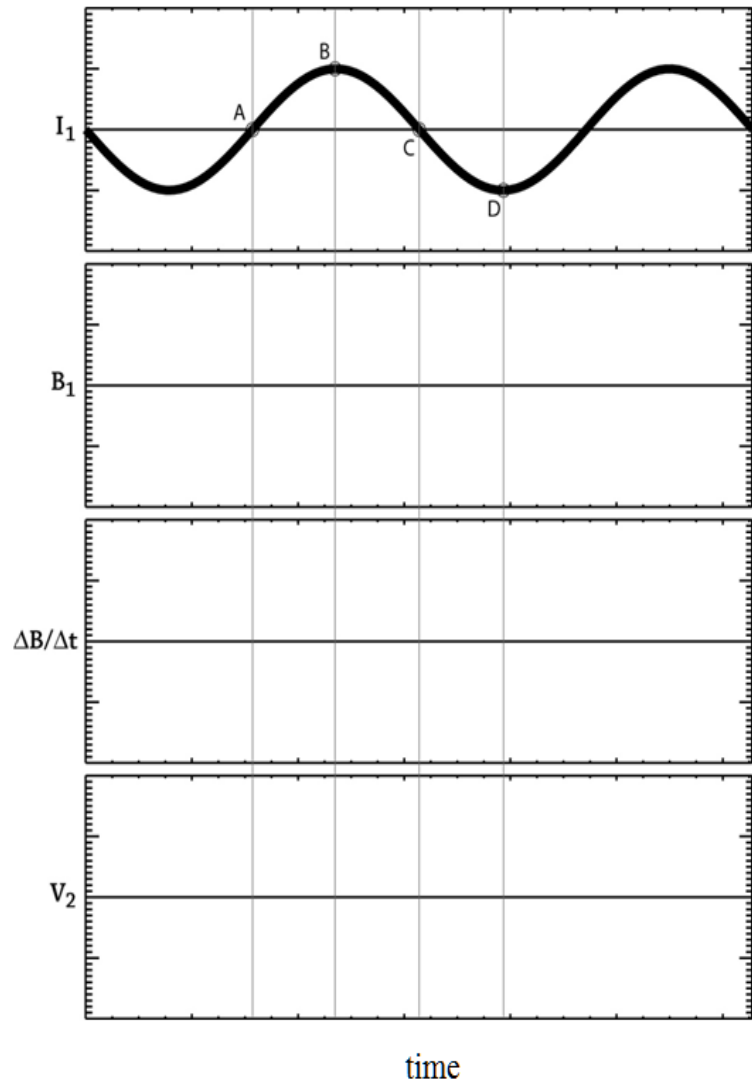

B. Now we will put together the setup described above. First, take the cable from the function generator, and connect it to a banana-plug adaptor. Next, connect a loop of wire across the two banana-plug terminals. This will be loop 1, which **produces** the magnetic field. Then take a second cable and make an identical loop. Use any adaptors that you need, and connect the two ends of the second wire to the oscilloscope. This will allow you to measure the time-varying voltage **induced** on loop 2. Turn the volts/div knob fully clockwise, to maximize the oscilloscope sensitivity. Turn on the function generator, and set it to something between 10-100 kHz, at maximum amplitude.

- Place the two loops next to each other – what happens?

Adjust the frequency higher and lower (by at least a factor of 10).

- Record what happens.
- Record actual numerical frequencies. Can you explain the behavior that you see?
- Based on Faraday's law, would you expect a higher **induced voltage** with a higher or lower source frequency? Why?

Bonus/challenge questions (if you have time...): By now you can see that the induced voltage (V_2) looks very similar to the source voltage (V_1), but if you look closely at your plots of V_2 and I_1 (a plot of V_1 would look just like the I_1 plot), you will see that there is a **phase shift** between the two plots. Namely, the peaks in V_2 are not exactly lined up with the peaks in V_1 . Why is this?

PART II: ELECTRIC MOTOR

At your table, you will find the parts needed to make an electric motor. You should have a wire coil on a bent-wire stand, a “telegraph key” switch, a bar magnet, and a battery set.

Look closely at the leads to the wire coil. You should notice that the coating is scratched off of **half** of the surface of the wire near the end. This is an insulating coating (called Kapton), so that when the Kapton is in contact with the wire stand, no current flows through the coil. When the scratched-off part comes in contact with the wire stand, current flows through the coil.

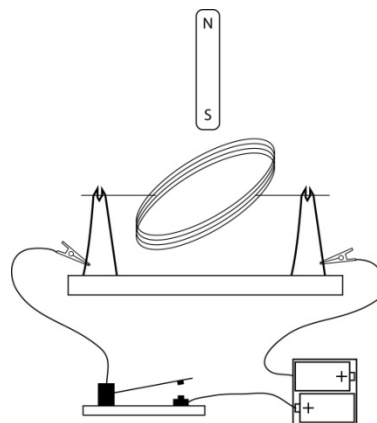

- Using the drawings as a template, sketch the magnetic field lines around the magnet.
 - Indicate the current direction (clockwise and counter-clockwise) on each coil.
 - Determine the direction of the force on the top and bottom parts of the coil when the current is going in each direction.
-
- What would happen if the motor was set up as pictured, but current was then allowed to flow through the coil at all times? (Namely, if the Kapton were completely stripped off rather than just half-stripped.)
 - How do the half-exposed leads (with half of the Kapton insulation scratched off) help the motor operate?

Put the motor together as pictured. Put one of the magnet poles near the coil and complete the circuit by closing the “telegraph key” switch. If the motor doesn’t spin, give it a gentle push to get it started.

- Note the direction of rotation.
- What do you expect to happen if you use the other pole of the magnet?
- Try running the motor using the other pole of the magnet. Does it match your prediction?

APPENDIX: USING THE OSCILLOSCOPE

Almost every AC measurement is done using an **oscilloscope**, which is a very useful tool for measuring voltages that are changing in time. Think of the oscilloscope just like the DMM we have used in previous labs – it measures voltage, but now it plots it out in time (voltage on the vertical axis and time on the horizontal axis). The grid that you see on the screen is used to measure the voltage and time of your signal – think of it like graph paper. Each little box on the grid is called a *division*, and you can adjust the scale of the voltage and time axes with the **volts/div** and the **sec/div** knobs, respectively. For example, if the volts/div knob is set to 5, this means that each box on the grid is equal to 5 volts.

There is small knob in the center of both the volts/div and time/div knobs, called the CAL or calibration knob. This should always be in the fully clockwise position for the volt/div and sec/div scale settings to be correct. Under the volts/div knob is a 3-position switch which reads (AC - ground - DC). This should be in the AC position for AC measurements.

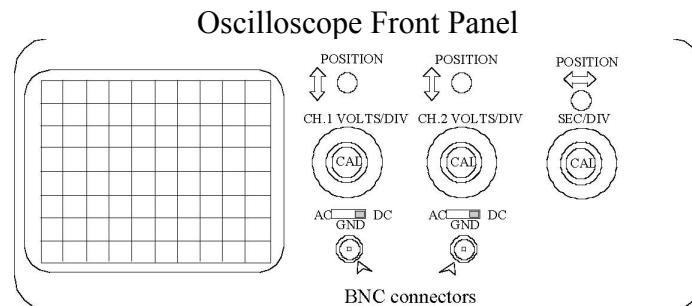

Whenever you use an oscilloscope, pay close attention to the horizontal and vertical scales (SEC/DIV and VOLTS/DIV).

When connecting the various components to each other, you will be using two different types of cables: coaxial cables with BNC connectors and single cables with banana-plug connectors. The different types of connectors are shown below:



BNC cable

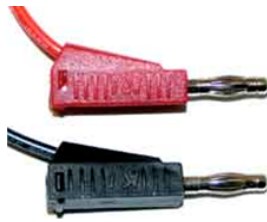

Banana plugs



Banana-to-BNC adapter

BNC cables are actually two cables in one. They are composed of an inner conductor, which is connected to the pin on the connector, and an outer conductor, which is connected to the metal housing. The outer conductor surrounds the inner conductor, so it is a **coaxial** cable. In many configurations, the outer conductor is always kept at 0 volts. (The outer conductor is sometimes referred to as “grounded” for this reason.) The two conductors are separated by an insulating material that is designed to maintain a constant spacing between them. You can think of this arrangement as a very long cylindrical capacitor where the two conductors that make up the capacitor are separated by a dielectric material whose properties are very tightly controlled. This configuration becomes very important for transmitting high-frequency voltages.